

रोल नं. 

--	--	--	--	--	--	--	--

  
Roll No. 

--	--	--	--	--	--	--	--

परीक्षार्थी कोड को उत्तर-पुस्तिका के मुख-पृष्ठ पर अवश्य लिखें ।

Candidates must write the Code on the title page of the answer-book.

- कृपया जाँच कर लें कि इस प्रश्न-पत्र में मुद्रित पृष्ठ **16** हैं ।
- प्रश्न-पत्र में दाहिने हाथ की ओर दिए गए कोड नम्बर को छात्र उत्तर-पुस्तिका के मुख-पृष्ठ पर लिखें ।
- कृपया जाँच कर लें कि इस प्रश्न-पत्र में **30** प्रश्न हैं ।
- कृपया प्रश्न का उत्तर लिखना शुरू करने से पहले, प्रश्न का क्रमांक अवश्य लिखें ।
- इस प्रश्न-पत्र को पढ़ने के लिए 15 मिनट का समय दिया गया है । प्रश्न-पत्र का वितरण पूर्वाह्न में 10.15 बजे किया जाएगा । 10.15 बजे से 10.30 बजे तक छात्र केवल प्रश्न-पत्र को पढ़ेंगे और इस अवधि के दौरान वे उत्तर-पुस्तिका पर कोई उत्तर नहीं लिखेंगे ।
- Please check that this question paper contains **16** printed pages.
- Code number given on the right hand side of the question paper should be written on the title page of the answer-book by the candidate.
- Please check that this question paper contains **30** questions.
- **Please write down the Serial Number of the question before attempting it.**
- 15 minutes time has been allotted to read this question paper. The question paper will be distributed at 10.15 a.m. From 10.15 a.m. to 10.30 a.m., the students will read the question paper only and will not write any answer on the answer-book during this period.

## भौतिक विज्ञान (सैद्धान्तिक)

### PHYSICS (Theory)

निर्धारित समय : 3 घण्टे

Time allowed : 3 hours

अधिकतम अंक : 70

Maximum Marks : 70



### सामान्य निर्देश :

- (i) सभी प्रश्न अनिवार्य हैं ।
- (ii) इस प्रश्न-पत्र में कुल 30 प्रश्न हैं । प्रश्न 1 से 8 तक के प्रश्न अति-लघुउत्तरीय प्रश्न हैं और प्रत्येक एक अंक का है ।
- (iii) प्रश्न 9 से 18 में प्रत्येक प्रश्न दो अंक का है, प्रश्न 19 से 27 में प्रत्येक प्रश्न तीन अंक का है और प्रश्न 28 से 30 में प्रत्येक प्रश्न पाँच अंक का है ।
- (iv) तीन अंकों वाले प्रश्नों में से एक मूल्यपरक प्रश्न है ।
- (v) प्रश्न-पत्र में समग्र पर कोई विकल्प नहीं है । तथापि, दो अंकों वाले एक प्रश्न में, तीन अंकों वाले एक प्रश्न में और पाँच अंकों वाले तीनों प्रश्नों में आन्तरिक चयन प्रदान किया गया है । ऐसे प्रश्नों में आपको दिए गए चयन में से केवल एक प्रश्न ही करना है ।
- (vi) कैलकुलेटर के उपयोग की अनुमति नहीं है । तथापि यदि आवश्यक हो तो आप लघुगणकीय सारणी का प्रयोग कर सकते हैं ।
- (vii) जहाँ आवश्यक हो आप निम्नलिखित भौतिक नियतांकों के मानों का उपयोग कर सकते हैं :

$$c = 3 \times 10^8 \text{ m/s}$$

$$h = 6.63 \times 10^{-34} \text{ Js}$$

$$e = 1.6 \times 10^{-19} \text{ C}$$

$$\mu_0 = 4\pi \times 10^{-7} \text{ T mA}^{-1}$$

$$\frac{1}{4\pi\epsilon_0} = 9 \times 10^9 \text{ N m}^2 \text{ C}^{-2}$$

$$m_e = 9.1 \times 10^{-31} \text{ kg}$$

### General Instructions :

- (i) All questions are compulsory.
- (ii) There are 30 questions in total. Questions No. 1 to 8 are very short answer type questions and carry one mark each.
- (iii) Questions No. 9 to 18 carry two marks each, questions 19 to 27 carry three marks each and questions 28 to 30 carry five marks each.
- (iv) One of the questions carrying three marks weightage is value based question.
- (v) There is no overall choice. However, an internal choice has been provided in one question of two marks, one question of three marks and all three questions of five marks each weightage. You have to attempt only one of the choices in such questions.
- (vi) Use of calculators is not permitted. However, you may use log tables if necessary.



(vii) You may use the following values of physical constants wherever necessary :

$$c = 3 \times 10^8 \text{ m/s}$$

$$h = 6.63 \times 10^{-34} \text{ Js}$$

$$e = 1.6 \times 10^{-19} \text{ C}$$

$$\mu_0 = 4\pi \times 10^{-7} \text{ T mA}^{-1}$$

$$\frac{1}{4\pi\epsilon_0} = 9 \times 10^9 \text{ N m}^2 \text{ C}^{-2}$$

$$m_e = 9.1 \times 10^{-31} \text{ kg}$$

1. ताप-वृद्धि के साथ किसी धातु की प्रतिरोधकता में वृद्धि की व्याख्या कैसे की जाती है ? 1  
How does one explain increase in resistivity of a metal with increase of temperature ?
2. उस शर्त (प्रतिबंध) का उल्लेख कीजिए जिसके अन्तर्गत, क्रॉसित विद्युत् और चुम्बकीय क्षेत्रों की उपस्थिति में, कोई इलेक्ट्रॉन अविक्षेपित गति करता रहेगा । 1  
Write the condition under which an electron will move undeflected in the presence of crossed electric and magnetic fields.
3. संचार की प्रसारण (ब्रौडकास्ट) विधि का एक उदाहरण दीजिए । 1  
Give one example of broadcast mode of communication.
4. किसी उत्तल लेंस पर एक समतल तरंग आपतित होती है । इससे निर्गत तरंगाग्र के आकार को दर्शाइए । 1  
Draw the shape of the wavefront coming out of a convex lens when a plane wave is incident on it.
5. दिया हुआ ग्राफ (आलेख), दो संधारित्रों  $C_1$  तथा  $C_2$  के लिए, विभवान्तर 'V' के साथ आवेश 'q' के परिवर्तन को दर्शाता है । दोनों संधारित्रों में पट्टिकाओं के बीच पृथक्कन (दूरी) समान (बराबर) है, किन्तु  $C_2$  में पट्टिकाओं का क्षेत्रफल  $C_1$  की तुलना में अधिक है । ग्राफ में कौन-सी रेखा (A या B)  $C_1$  के संगत है ? अपने उत्तर के लिए कारण लिखिए । 1

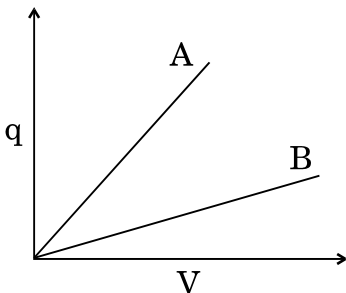

The given graph shows variation of charge 'q' versus potential difference 'V' for two capacitors  $C_1$  and  $C_2$ . Both the capacitors have same plate separation but plate area of  $C_2$  is greater than that of  $C_1$ . Which line (A or B) corresponds to  $C_1$  and why ?

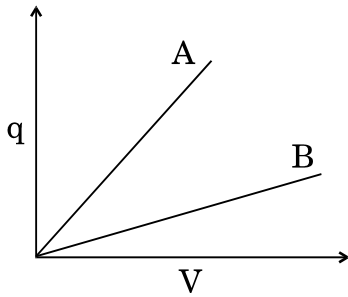

6. किसी चालक की लम्बाई ' $l$ ' है । इसके दो सिरों के बीच ' $V$ ' विभवान्तर है । इस चालक में आवेश वाहकों के अपवाह वेग के लिए एक व्यंजक लिखिए । 1

Write the expression for the drift velocity of charge carriers in a conductor of length ' $l$ ' across which a potential difference ' $V$ ' is applied.

7. यदि एक चुम्बक को आरेख में दर्शाए गए अनुसार, संधारित्र की ओर ले जाएँ, तो प्लेट (पट्टिका) A की ध्रुवता क्या होगी ? 1

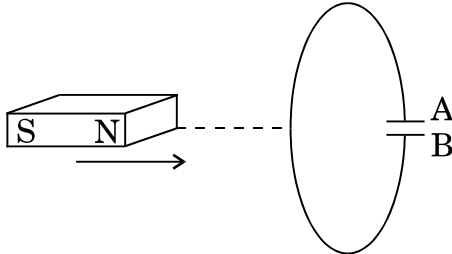

Predict the polarity of the plate A of the capacitor, when a magnet is moved towards it, as is shown in the figure.

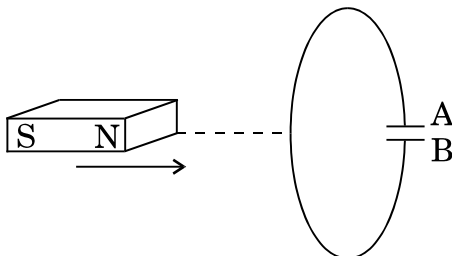

8. संचार व्यवस्था में 'मॉडुलन सूचकांक' पद को परिभाषित कीजिए । 1

Define the term 'modulation index' in communication system.

9. एक गोले  $S_1$  की त्रिज्या  $r_1$  है और इसमें एक नेट आवेश  $Q$  परिबद्ध है। यदि एक अन्य संकेन्द्री गोले  $S_2$  की त्रिज्या  $r_2$  ( $r_2 > r_1$ ) है, जिसमें  $2Q$  आवेश परिबद्ध है, तो  $S_1$  तथा  $S_2$  से गुज़रने वाले विद्युत् फ्लक्स का अनुपात ज्ञात कीजिए। यदि  $S_2$  के रिक्त स्थान में वायु के स्थान पर,  $K$  परावैद्युतांक वाला माध्यम भर दिया जाए, तो  $S_1$  गोले से गुज़रने वाले विद्युत् फ्लक्स में क्या परिवर्तन होगा ?

2

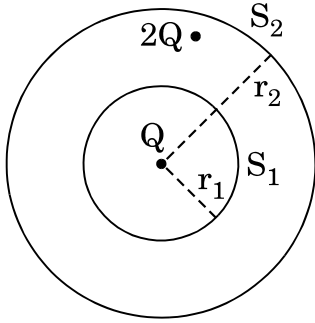

A sphere  $S_1$  of radius  $r_1$  encloses a net charge  $Q$ . If there is another concentric sphere  $S_2$  of radius  $r_2$  ( $r_2 > r_1$ ) enclosing charge  $2Q$ , find the ratio of the electric flux through  $S_1$  and  $S_2$ . How will the electric flux through sphere  $S_1$  change if a medium of dielectric constant  $K$  is introduced in the space inside  $S_2$  in place of air ?

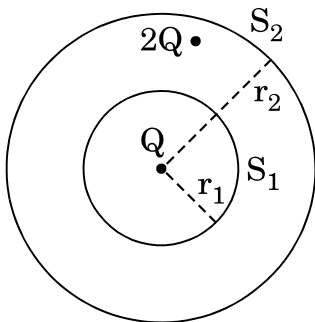

10. दो बिन्दु आवेश  $q$  तथा  $-2q$  एक-दूसरे से 'd' दूरी पर स्थित हैं। आवेश ' $q$ ' के सापेक्ष, एक ऐसे बिन्दु की अवस्थिति ज्ञात कीजिए, जहाँ पर आवेशों के इस निकाय के कारण विभव शून्य हो।

2

अथवा



एक विद्युत् द्विध्रुव को किसी एकसमान विद्युत्-क्षेत्र  $\vec{E}$  में ऐसे रखा गया है कि द्विध्रुव का द्विध्रुव आघूर्ण  $\vec{p}$  विद्युत्-क्षेत्र के समान्तर है। ज्ञात कीजिए

- द्विध्रुव को इतना घुमाने में किया गया कार्य जिससे उसके द्विध्रुव आघूर्ण की दिशा  $\vec{E}$  की दिशा के विपरीत हो जाए।
- द्विध्रुव का वह अभिविन्यास (स्थिति) जिसके लिए उस पर लगने वाला बल-आघूर्ण (टॉर्क) अधिकतम हो जाए।

2

Two point charges  $q$  and  $-2q$  are kept 'd' distance apart. Find the location of the point relative to charge ' $q$ ' at which potential due to this system of charges is zero.

**OR**

An electric dipole is placed in a uniform electric field  $\vec{E}$  with its dipole moment  $\vec{p}$  parallel to the field. Find

- the work done in turning the dipole till its dipole moment points in the direction opposite to  $\vec{E}$ .
- the orientation of the dipole for which the torque acting on it becomes maximum.

11. (a) विद्युत्-चुम्बक किसी स्थायी चुम्बक से किस प्रकार भिन्न होता है ?

(b) विद्युत्-चुम्बक बनाने के लिए उपयुक्त पदार्थ के दो गुणधर्म लिखिए।

2

(a) How is an electromagnet different from a permanent magnet ?

(b) Write two properties of a material which make it suitable for making electromagnets.

12. एक इलेक्ट्रॉन  $2.4 \times 10^8$  m/s की स्थिर चाल से नाभिक की परिक्रमा कर रहा है। इससे संबद्ध दे ब्रॉग्ली तरंगदैर्घ्य का मान ज्ञात कीजिए।

2

An electron is revolving around the nucleus with a constant speed of  $2.4 \times 10^8$  m/s. Find the de Broglie wavelength associated with it.

13. एक सेल जिसका आन्तरिक प्रतिरोध ' $r$ ' है, के विद्युत्-वाहक बल (ई.एम.एफ) ( $\epsilon$ ) तथा टर्मिनल वोल्टता (V) के बीच अन्तर (भेद) लिखिए। सेल से ली गई विद्युत् धारा (I) के साथ उसकी टर्मिनल वोल्टता (V) में परिवर्तन को दर्शाने के लिए एक ग्राफ (आलेख) बनाइए। इस ग्राफ के उपयोग से, किसी सेल के आन्तरिक प्रतिरोध का निर्धारण कैसे किया जा सकता है ?

2

Distinguish between emf ( $\epsilon$ ) and terminal voltage (V) of a cell having internal resistance ' $r$ '. Draw a plot showing the variation of terminal voltage (V) vs the current (I) drawn from the cell. Using this plot, how does one determine the internal resistance of the cell ?



14. (i) किसी I धारावाही अल्पांश  $d\vec{l}$  से  $\vec{r}$  दूरी पर, चुम्बकीय क्षेत्र के लिए बायो – सावर्ट नियम को सदिश रूप में लिखिए ।

(ii) एक वृत्ताकार पाश (लूप) के केन्द्र पर चुम्बकीय क्षेत्र के परिमाण (मान) के लिए व्यंजक लिखिए, यदि पाश (लूप) की त्रिज्या  $r$  है और इससे एक अचर (स्थिर) धारा I प्रवाहित हो रही है । इस धारा-पाश के कारण उत्पन्न क्षेत्र रेखाओं को दर्शाइए ।

2

(i) State Biot – Savart law in vector form expressing the magnetic field due to an element  $d\vec{l}$  carrying current I at a distance  $\vec{r}$  from the element.

(ii) Write the expression for the magnitude of the magnetic field at the centre of a circular loop of radius  $r$  carrying a steady current I. Draw the field lines due to the current loop.

15. (a) 'निरोधी विभव' पद की परिभाषा दीजिए ।

(b) दो भिन्न-भिन्न आवृत्तियों  $\nu_1$  एवं  $\nu_2$  ( $\nu_2 > \nu_1$ ), किन्तु समान तीव्रता के दो प्रकाश पुंजों के लिए, ऐनोड विभव के फलन के रूप में प्रकाश-विद्युत् धारा के परिवर्तन को दर्शाने के लिए ग्राफ (आलेख) बनाइए ।

2

(a) Define the term 'stopping potential'.

(b) Plot a graph showing the variation of photoelectric current as a function of anode potential for two light beams of same intensity but of different frequencies,  $\nu_1$  and  $\nu_2$  ( $\nu_2 > \nu_1$ ).

16. (a) OR गेट के लिए सत्यमान सारणी तथा इसका तर्क प्रतीक बनाइए ।

(b) नीचे दर्शाए गए निवेशी तरंग-रूपों A तथा B का AND गेट में निवेशन किया जाता है । निर्गत तरंग-रूप को ज्ञात कीजिए ।

2

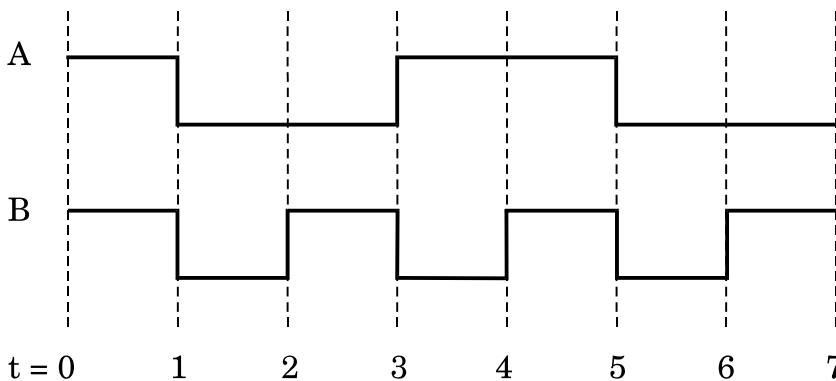

- (a) Write the truth table for an OR gate and draw its logic symbol.  
 (b) The input waveforms A and B, shown below, are fed to an AND gate. Find the output waveform.

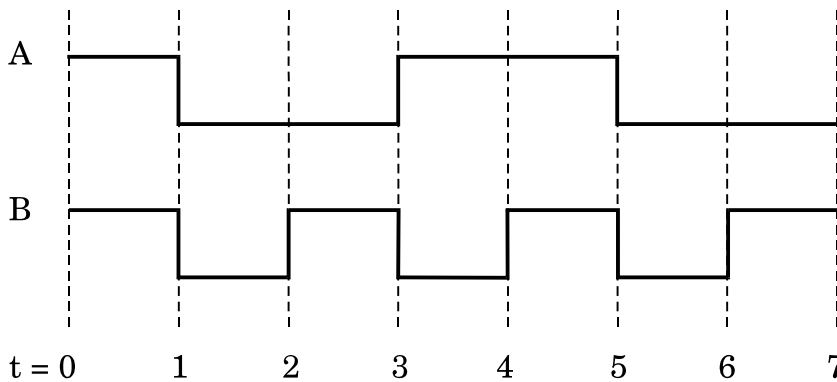

17. इन्द्रधनुष के दिखाई देने (प्रेक्षण) के लिए क्या शर्तें (प्रतिबंध) हैं ? उपयुक्त आरेखों की सहायता से दर्शाए कि इन्द्रधनुष के बनने को कैसे समझा जा सकता है ।

2

Write the conditions for observing a rainbow. Show, by drawing suitable diagrams, how one understands the formation of a rainbow.

18. आरेख में एक श्रेणी LCR परिपथ दर्शाया गया है जो 250 V के एक परिवर्ती आवृत्ति के स्रोत से जुड़ा है तथा  $L = 40 \text{ mH}$ ,  $C = 100 \mu\text{F}$  तथा  $R = 50 \Omega$  है ।

निर्धारित कीजिए

- (i) स्रोत की वह आवृत्ति जिससे परिपथ में अनुनाद हो;  
 (ii) परिपथ का गुणवत्ता गुणांक (Q) ।

2

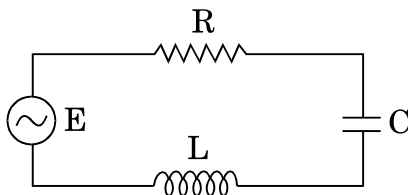

The figure shows a series LCR circuit connected to a variable frequency 250 V source with  $L = 40 \text{ mH}$ ,  $C = 100 \mu\text{F}$  and  $R = 50 \Omega$ .

Determine

- (i) the source frequency which derives the circuit in resonance;  
 (ii) the quality factor (Q) of the circuit.

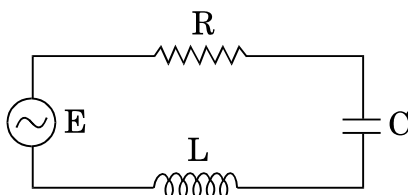



19. (a) विभवमापी (पोटेन्शियोमीटर) किस सिद्धान्त पर आधारित है, उल्लेख कीजिए। इसमें, (i) लम्बे तार का, (ii) एकसमान अनुप्रस्थ-काट क्षेत्रफल (मोटाई) के तार का तथा (iii) प्राथमिक सेलों से अधिक विद्युत्-वाहक बल (ई.एम.एफ) के मानक (चालक) सेल का, उपयोग क्यों किया जाता है ?

(b) विभवमापी (पोटेन्शियोमीटर) के किसी प्रयोग में, यदि तार के अनुप्रस्थ-काट का क्षेत्रफल एक सिरे से दूसरे सिरे की ओर एकसमान रूप से बढ़ता जाए, तो तार के एक सिरे से इस लम्बाई में वृद्धि के साथ, विभव प्रवणता के परिवर्तन को दर्शाने के लिए एक ग्राफ बनाइए।

3

(a) State the underlying principle of a potentiometer. Why is it necessary to (i) use a long wire, (ii) have uniform area of cross-section of the wire and (iii) use a driving cell whose emf is taken to be greater than the emfs of the primary cells ?

(b) In a potentiometer experiment, if the area of the cross-section of the wire increases uniformly from one end to the other, draw a graph showing how potential gradient would vary as the length of the wire increases from one end.

20. (a) किसी d.c. स्रोत के सिरों से जुड़े एक संधारित्र से श्रेणीक्रम में एक ऐमीटर को जोड़ा गया है। संधारित्र को आवेशित करते समय ऐमीटर में क्षणिक विक्षेप क्यों होता है ? संधारित्र के पूर्ण रूप से आवेशित हो जाने पर विक्षेप क्या होगा ?

(b) विस्थापन धारा से संबद्ध पद को सम्मिलित करते हुए, ऐम्पियर के परिपथीय नियम के सामान्यीकृत रूप को कैसे प्राप्त किया जाता है ?

3

(a) A capacitor is connected in series to an ammeter across a d.c. source. Why does the ammeter show a momentary deflection during the charging of the capacitor ? What would be the deflection when it is fully charged ?

(b) How is the generalized form of Ampere's circuital law obtained to include the term due to displacement current ?



21. आरेख में दर्शाए गए अनुसार एक समबाहु त्रिभुज ABC के दो शीर्षों 'B' तथा 'C' पर क्रमशः दो आवेश  $+3q$  तथा  $-4q$  रखे गए हैं। इस त्रिभुज की भुजा 'a' है। इन दो आवेशों के कारण शीर्ष A पर परिणामी विद्युत्-क्षेत्र के (i) परिमाण (मान) तथा (ii) दिशा के लिए व्यंजक प्राप्त कीजिए।

3

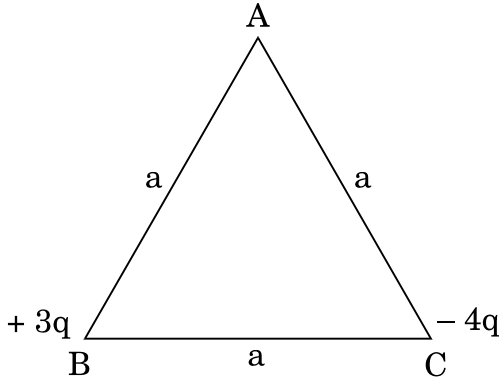

Two point charges  $+3q$  and  $-4q$  are placed at the vertices 'B' and 'C' of an equilateral triangle ABC of side 'a' as given in the figure. Obtain the expression for (i) the magnitude and (ii) the direction of the resultant electric field at the vertex A due to these two charges.

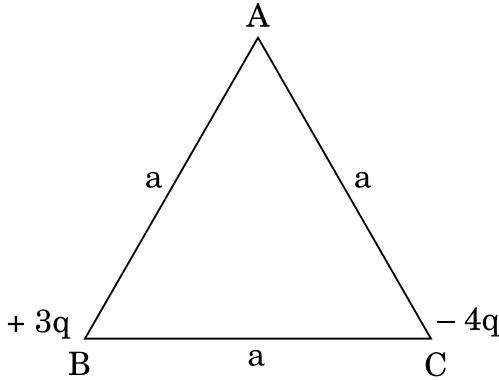

22. अर्नब अपने मित्र से मोबाइल पर बहुत लम्बे समय तक वार्तालाप करता रहा। वार्तालाप समाप्त होने पर, उसकी बहिन अनिता ने उसको राय दी कि इतने लम्बे समय तक वार्तालाप करना हो, तो लैंड लाइन से करना अधिक अच्छा होगा।

निम्नांकित प्रश्नों के उत्तर दीजिए :

- लम्बे समय तक मोबाइल फोन का उपयोग करना हानिकारक क्यों समझा जाता है ?
- अर्नब की बहिन की सलाह किन मूल्यों का प्रदर्शन करती है ?
- 10 kHz आवृत्ति के एक संदेश सिग्नल (संकेत) का अध्यारोपण, 1 MHz आवृत्ति की वाहक तरंग का मॉडुलन के लिए किया जाता है। उत्पन्न पार्श्व-बैंड ज्ञात कीजिए।

3



Arnab was talking on his mobile to his friend for a long time. After his conversation was over, his sister Anita advised him that if his conversation was of such a long duration, it would be better to talk through a land line.

Answer the following questions :

- Why is it considered harmful to use a mobile phone for a long duration ?
- Which values are reflected in the advice of his sister Anita ?
- A message signal of frequency 10 kHz is superposed to modulate a carrier wave of frequency 1 MHz. Determine the sidebands produced.

23.

- टोरोइड किसी परिनालिका से किस प्रकार भिन्न होता है ?
- ऐम्पियर के परिपथीय नियम के उपयोग द्वारा, किसी टोरोइड के अन्दर चुम्बकीय क्षेत्र का मान प्राप्त कीजिए ।
- दर्शाएँ कि एक आदर्श टोरोइड में, (i) टोरोइड के भीतर तथा (ii) टोरोइड के बाहर, खुले क्षेत्र में किसी बिन्दु पर, चुम्बकीय क्षेत्र शून्य होता है ।

3

अथवा

नाभिक की परिक्रमा करते हुए इलेक्ट्रॉन के चुम्बकीय आघूर्ण ( $\vec{\mu}$ ) के लिए, उसके कोणीय संवेग ( $\vec{l}$ ) के पदों में, एक व्यंजक व्युत्पन्न कीजिए । इलेक्ट्रॉन की चुम्बकीय आघूर्ण की दिशा, उसके कोणीय संवेग के सापेक्ष क्या है ?

3

- How is a toroid different from a solenoid ?
- Use Ampere's circuital law to obtain the magnetic field inside a toroid.
- Show that in an ideal toroid, the magnetic field (i) inside the toroid and (ii) outside the toroid at any point in the open space is zero.

OR

Derive an expression for the magnetic moment ( $\vec{\mu}$ ) of an electron revolving around the nucleus in terms of its angular momentum ( $\vec{l}$ ). What is the direction of the magnetic moment of the electron with respect to its angular momentum ?

24.

- किसी रेडियोऐक्टिव नाभिक की 'औसत आयु' तथा 'अर्ध-आयु' के बीच सम्बन्ध को लिखिए ।
- ${}_{38}^{90}\text{Sr}$  की अर्ध-आयु 28 वर्ष है । इस समस्थानिक के 15 मिलीग्राम की ऐक्टिवता का परिकलन कीजिए । दिया गया है कि 1 ग्राम  ${}_{27}^{80}\text{Sr}$  में  $75 \times 10^{20}$  परमाणु होते हैं ।

3



- (i) Write the relation between 'average life' and 'half-life' of a radioactive nucleus.
- (ii) The half-life of  ${}_{38}^{90}\text{Sr}$  is 28 years. Calculate the activity of 15 mg of this isotope. Given that 1 g of  ${}_{27}^{80}\text{Sr}$  contains  $75 \times 10^{20}$  atoms.

25. (a) दो कला-संबद्ध एकवर्णी स्रोतों से निर्गमित तरंगों के विस्थापनों को निम्न प्रकार निरूपित किया जाता है :

$$y_1 = a \cos \omega t \text{ तथा}$$

$$y_2 = a \cos (\omega t + \phi),$$

जहाँ  $\phi$  दो विस्थापनों के बीच कलान्तर है। दर्शाइए कि इन तरंगों के अध्यारोपण के कारण किसी बिन्दु पर परिणामी तीव्रता का मान होगा,  $I = 4 I_0 \cos^2 \phi/2$ , जहाँ  $I_0 = a^2$ .

- (b) इससे संपोषी तथा विनाशी व्यतिकरण के लिए शर्तें प्राप्त कीजिए।

3

- (a) Two monochromatic waves emanating from two coherent sources have the displacements represented by

$$y_1 = a \cos \omega t \text{ and}$$

$$y_2 = a \cos (\omega t + \phi),$$

where  $\phi$  is the phase difference between the two displacements. Show that the resultant intensity at a point due to their superposition is given by  $I = 4 I_0 \cos^2 \phi/2$ , where  $I_0 = a^2$ .

- (b) Hence obtain the conditions for constructive and destructive interference.

26. हाइड्रोजन परमाणु की मूल (निम्नतम) अवस्था ऊर्जा का मान  $-13.6 \text{ eV}$  है और बोर त्रिज्या  $= 0.53 \text{ \AA}$  है। परिकलन कीजिए

- (i) इलेक्ट्रॉन को मूल अवस्था से द्वितीय उत्तेजित अवस्था तक जाने के लिए आवश्यक ऊर्जा।
- (ii) द्वितीय (दूसरी) उत्तेजित अवस्था में परमाणु की (a) गतिज ऊर्जा और (b) कक्षीय त्रिज्या।

3



The value of ground state energy of hydrogen atom is  $-13.6$  eV and Bohr radius is  $0.53 \text{ \AA}$ . Calculate

- (i) the energy required to move an electron from the ground state to the second excited state.
- (ii) (a) the kinetic energy and (b) the orbital radius in the second excited state of the atom.

27. (a)  $I_0$  तीव्रता का अध्रुवित प्रकाश दो पोलैरॉइडों  $P_1$  तथा  $P_2$  से होकर गुज़रता है, और इस प्रकार  $P_2$  की पारित-अक्ष  $P_1$  की पारित-अक्ष से  $\theta^\circ$  कोण बनाती है। इस कोण ( $\theta$ ) के शून्य डिग्री से  $180^\circ$  तक परिवर्तित होने से,  $P_2$  से पारगमित प्रकाश की तीव्रता में परिवर्तन को दर्शाने के लिए एक ग्राफ (आलेख) बनाइए।

(b)  $P_1$  और  $P_2$  के बीच में एक तीसरा पोलैरॉइड  $P_3$  इस प्रकार रखा जाता है कि  $P_3$  की पारित-अक्ष  $P_1$  से  $\beta$  कोण बनाती है। यदि  $P_1$ ,  $P_2$  तथा  $P_3$  से पारगमित (प्रेषित) प्रकाश की तीव्रताएँ क्रमशः  $I_1$ ,  $I_2$  तथा  $I_3$  हों, तो कोण  $\theta$  और  $\beta$  के उस मान को ज्ञात कीजिए जिसके लिए  $I_1 = I_2 = I_3$ .

3

(a) Unpolarised light of intensity  $I_0$  passes through two polaroids  $P_1$  and  $P_2$  such that pass axis of  $P_2$  makes an angle  $\theta$  with the pass axis of  $P_1$ . Plot a graph showing the variation of intensity of light transmitted through  $P_2$  as the angle  $\theta$  varies from zero to  $180^\circ$ .

(b) A third polaroid  $P_3$  is placed between  $P_1$  and  $P_2$  with pass axis of  $P_3$  making an angle  $\beta$  with that of  $P_1$ . If  $I_1$ ,  $I_2$  and  $I_3$  represent the intensities of light transmitted by  $P_1$ ,  $P_2$  and  $P_3$ , determine the values of angle  $\theta$  and  $\beta$  for which  $I_1 = I_2 = I_3$ .

28. (a) किसी p-n संधि डायोड के  $V - I$  अभिलक्षणों का अध्ययन करने के लिए परिपथ व्यवस्था बनाइए, यदि डायोड (i) अग्रदिशिक बायस में हो तथा (ii) पश्चदिशिक बायस में हो। संक्षेप में स्पष्ट कीजिए कि किसी डायोड के प्ररूपी (टिपिकल) अभिलक्षण कैसे प्राप्त किए जाते हैं और इन अभिलक्षणों को दर्शाइए।

(b) प्रकाशिक संकेतों (सिग्नलों) के संसूचन (डिटेक्शन) के लिए प्रयुक्त, फोटो डायोड की कार्यविधि को एक आवश्यक परिपथ आरेख द्वारा स्पष्ट कीजिए।

5

अथवा



- (a) एक n-p-n ट्रांज़िस्टर के लिए परिपथ आरेख बनाइए, जिसमें उत्सर्जक-आधार संधि अग्रदिशिक बायस में हो तथा संग्राहक-आधार संधि पश्चदिशिक बायस में है। संक्षेप में वर्णन कीजिए कि ट्रांज़िस्टर में आवेश वाहकों की गति से, उत्सर्जक धारा ( $I_E$ ), आधार धारा ( $I_B$ ) तथा संग्राहक धारा ( $I_C$ ) कैसे बनती हैं। इससे संबंध,  $I_E = I_B + I_C$  को व्युत्पन्न कीजिए।
- (b) एक परिपथ आरेख द्वारा स्पष्ट कीजिए कि ट्रांज़िस्टर, प्रवर्धक की भाँति कैसे कार्य करता है।

5

- (a) Draw the circuit arrangement for studying the V – I characteristics of a p-n junction diode in (i) forward and (ii) reverse bias. Briefly explain how the typical V – I characteristics of a diode are obtained and draw these characteristics.
- (b) With the help of necessary circuit diagram explain the working of a photo diode used for detecting optical signals.

### OR

- (a) Draw the circuit diagram of an n-p-n transistor with emitter-base junction forward biased and collector-base junction reverse biased. Describe briefly how the motion of charge carriers in the transistor constitutes the emitter current ( $I_E$ ), the base current ( $I_B$ ) and the collector current ( $I_C$ ). Hence deduce the relation  $I_E = I_B + I_C$ .
- (b) Explain with the help of circuit diagram how a transistor works as an amplifier.

29. (a) किसी ट्रांसफॉर्मर में प्राथमिक एवं द्वितीयक कुंडलियों को लपेटने की व्यवस्था को एक आरेख से दर्शाइए जब दो कुंडलियाँ एक-दूसरे के ऊपर लपेटी गई हैं।
- (b) ट्रांसफॉर्मर की कार्यविधि के सिद्धान्त का उल्लेख कीजिए और द्वितीयक कुंडली में वोल्टता का प्राथमिक कुंडली में वोल्टता के साथ अनुपात के लिए एक व्यंजक प्राप्त कीजिए :
- (i) द्वितीयक कुंडली तथा प्राथमिक कुंडली में फेरों की संख्या के पदों में
- (ii) प्राथमिक तथा द्वितीयक कुंडलियों में विद्युत् धारा के पदों में।
- (c) उपर्युक्त सम्बन्धों को व्युत्पन्न (प्राप्त) करने के लिए प्रयुक्त मुख्य परिकल्पना का उल्लेख कीजिए।
- (d) वास्तविक ट्रांसफॉर्मरों में ऊर्जा क्षय के कोई दो कारण लिखिए।

5

### अथवा



धातु की एक छड़ की लम्बाई  $l$  है और इसका प्रतिरोध  $R$  है। इसका एक सिरा धातु के एक वृत्ताकार छल्ले (रिंग) के केन्द्र पर कीलित (हिंज़) है, और दूसरा छल्ले की परिधि पर टिका रहता है। छल्ले की त्रिज्या  $l$  है। इस छड़ को  $\nu$  आवृत्ति से घुमाया जाता है। छड़ की घूर्णन अक्ष, छल्ले के केन्द्र से गुज़रती है और छल्ले के समतल के लम्बवत् है। एक अचर, एकसमान चुम्बकीय क्षेत्र  $B$ , सर्वत्र विद्यमान है, जिसकी दिशा छड़ की घूर्णन अक्ष के समान्तर है।

- छड़ में प्रेरित विद्युत्-वाहक बल (ई.एम.एफ) तथा विद्युत् धारा के लिए एक व्यंजक व्युत्पन्न कीजिए।
  - छड़ में प्रेरित विद्युत् धारा तथा उपस्थित चुम्बकीय क्षेत्र के कारण, छड़ पर लगने वाले बल के परिमाण (मान) तथा दिशा के लिए एक व्यंजक प्राप्त कीजिए।
  - इससे छड़ को घुमाने के लिए आवश्यक शक्ति के लिए एक व्यंजक प्राप्त कीजिए।
- 5
- Draw a schematic arrangement for winding of primary and secondary coil in a transformer when the two coils are wound on top of each other.
  - State the underlying principle of a transformer and obtain the expression for the ratio of secondary to primary voltage in terms of the
    - number of secondary and primary windings and
    - primary and secondary currents.
  - Write the main assumption involved in deriving the above relations.
  - Write any two reasons due to which energy losses may occur in actual transformers.

**OR**

A metallic rod of length  $l$  and resistance  $R$  is rotated with a frequency  $\nu$ , with one end hinged at the centre and the other end at the circumference of a circular metallic ring of radius  $l$ , about an axis passing through the centre and perpendicular to the plane of the ring. A constant and uniform magnetic field  $B$  parallel to the axis is present everywhere.

- Derive the expression for the induced emf and the current in the rod.
- Due to the presence of the current in the rod and of the magnetic field, find the expression for the magnitude and direction of the force acting on this rod.
- Hence obtain the expression for the power required to rotate the rod.



30. (a) एक बिन्दु वस्तु को किसी उभयोत्तल लेंस के सामने रखा गया है, (लेंस का वायु के सापेक्ष अपवर्तनांक  $n = n_2/n_1$ ) लेंस के दो गोलीय पृष्ठों की वक्रता त्रिज्याएँ  $R_1$  तथा  $R_2$  हैं। लेंस की प्रथम तथा फिर द्वितीय पृष्ठ पर अपवर्तन के कारण प्रकाश की किरणों का मार्ग दर्शाते हुए वस्तु का एक वास्तविक प्रतिबिम्ब प्राप्त कीजिए। इससे किसी पतले लेंस के लिए 'लेंस-मेकर सूत्र' प्राप्त कीजिए।
- (b) एक उभयोत्तल लेंस के दोनों पृष्ठों की वक्रता त्रिज्याएँ आपस में बराबर हैं। लेंस के पदार्थ का अपवर्तनांक 1.55 है। लेंस की फोकस दूरी 20 cm होने के लिए लेंस के पृष्ठों की वक्रता त्रिज्या का मान ज्ञात कीजिए।

5

### अथवा

- (a) किसी अपवर्ती दूरदर्शक द्वारा, दूर स्थित किसी वस्तु का प्रतिबिम्ब बनना दर्शाने के लिए एक नामांकित किरण आरेख बनाइए। यदि इस दूरदर्शक द्वारा अन्तिम प्रतिबिम्ब अनन्त पर बनता है, तो उसकी आवर्धन क्षमता के लिए एक व्यंजक व्युत्पन्न कीजिए।
- (b) किसी अपवर्ती दूरदर्शक के दो लेंसों की फोकस दूरियों का योगफल 105 cm है। एक लेंस की फोकस दूरी दूसरे लेंस से 20 गुना है। यदि अन्तिम प्रतिबिम्ब अनन्त पर बनता है, तो दूरदर्शक के कारण कुल आवर्धन ज्ञात कीजिए।

5

- (a) A point object is placed in front of a double convex lens (of refractive index  $n = n_2/n_1$  with respect to air) with its spherical faces of radii of curvature  $R_1$  and  $R_2$ . Show the path of rays due to refraction at first and subsequently at the second surface to obtain the formation of the real image of the object.

Hence obtain the lens-maker's formula for a thin lens.

- (b) A double convex lens having both faces of the same radius of curvature has refractive index 1.55. Find out the radius of curvature of the lens required to get the focal length of 20 cm.

### OR

- (a) Draw a labelled ray diagram showing the image formation of a distant object by a refracting telescope. Deduce the expression for its magnifying power when the final image is formed at infinity.
- (b) The sum of focal lengths of the two lenses of a refracting telescope is 105 cm. The focal length of one lens is 20 times that of the other. Determine the total magnification of the telescope when the final image is formed at infinity.

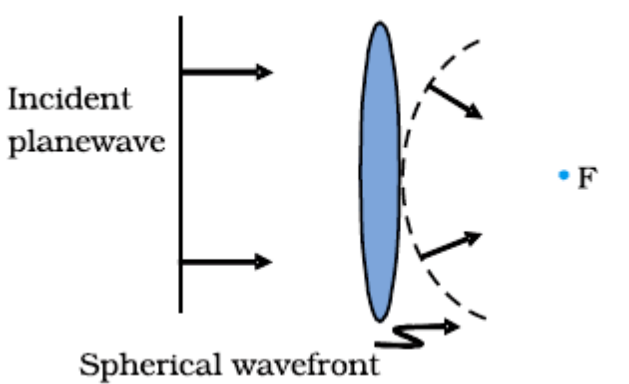

**MARKING SCHEME**  
**SET 55/2 (Compartment)**

Q.No.	Expected Answer/Value Points	Marks	Total Marks								
1.	With increase in temperature, the relaxation time ( average time between successive collisions) decreases and hence resistivity increases. <b>Alternatively:</b> Resistivity $\rho \left( = \frac{m}{ne^2\tau} \right)$ increases as $\tau$ decreases with increase in temperature.	1	1								
2.	$v = \frac{E}{B}$ where $v$ is speed of electron <b>Alternatively:</b> $ \vec{F}_E  =  \vec{F}_B $	1	1								
3.	Radio, Television ( <b>Any one</b> )	1	1								
4.		1	1								
5.	Line B Since slope ( $q/V$ ) of B is lesser than that of A.	$\frac{1}{2}$ $\frac{1}{2}$	1								
6.	$v_d = \frac{eV}{m\ell} \tau$	1	1								
7.	A has positive polarity	1	1								
8.	Modulation Index is defined as the ratio of amplitude of modulating signal to the amplitude of carrier wave i.e. $\mu = \frac{A_m}{A_c}$	1	1								
9.	<table border="1" style="width: 100%; border-collapse: collapse;"> <tr> <td>Flux through <math>S_1</math></td> <td style="text-align: right;"><math>\frac{1}{2}</math></td> </tr> <tr> <td>Flux through <math>S_2</math></td> <td style="text-align: right;"><math>\frac{1}{2}</math></td> </tr> <tr> <td>Ratio</td> <td style="text-align: right;"><math>\frac{1}{2}</math></td> </tr> <tr> <td>Flux through <math>S_1</math> with dielectric median</td> <td style="text-align: right;"><math>\frac{1}{2}</math></td> </tr> </table> <p>Flux through <math>S_1</math>, <math>\Phi_1 = \frac{Q}{\epsilon_0}</math>  Flux through <math>S_2</math>, <math>\Phi_2 = \frac{Q+2Q}{\epsilon_0} = \frac{3Q}{\epsilon_0}</math>  Ratio of flux = 1:3  No change in flux through <math>S_1</math> with dielectric medium inside the sphere <math>S_2</math>.</p>	Flux through $S_1$	$\frac{1}{2}$	Flux through $S_2$	$\frac{1}{2}$	Ratio	$\frac{1}{2}$	Flux through $S_1$ with dielectric median	$\frac{1}{2}$	$\frac{1}{2}$ $\frac{1}{2}$ $\frac{1}{2}$ $\frac{1}{2}$	2
Flux through $S_1$	$\frac{1}{2}$										
Flux through $S_2$	$\frac{1}{2}$										
Ratio	$\frac{1}{2}$										
Flux through $S_1$ with dielectric median	$\frac{1}{2}$										

10.

Formula	1/2
Substitution and simplification	1
Result	1/2

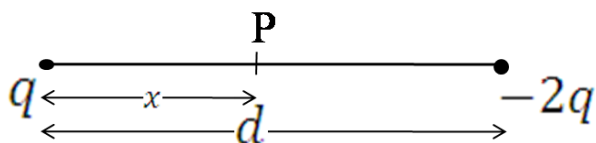

Let P be the required point at a distance  $x$  from charge  $q$

$$\therefore \frac{1}{4\pi\epsilon_0} \frac{q}{x} + \frac{1}{4\pi\epsilon_0} \frac{(-2q)}{(d-x)} = 0$$

$$\frac{1}{x} = \frac{2}{d-x}$$

$$x = \frac{d}{3}$$

required point is at a distance  $\frac{d}{3}$  from charge  $q$

**Alternatively:**

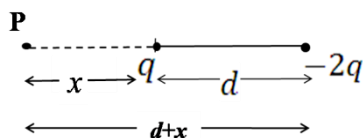

$$\frac{1}{4\pi\epsilon_0} \frac{q}{x} = \frac{1}{4\pi\epsilon_0} \frac{2q}{d+x}$$

$$2x = x + d \text{ or } x = d$$

At distance  $d$  towards left of charge  $q$

**OR**

(i) Work Done	1
(ii) Orientation	1

(i) We have  $W = \int_{\theta_1}^{\theta_2} \tau d\theta$

$$\begin{aligned} \therefore W &= \int_0^\pi pE \sin\theta d\theta \\ &= pE [-\cos\theta]_0^\pi \\ &= -2pE \end{aligned}$$

(ii)  $\therefore \tau = PE \sin\theta$  for  $\theta = \frac{\pi}{2}$ ,  $\tau$  is maximum

**Alternatively:**

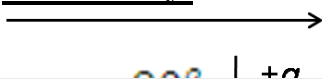

1/2

1/2

1/2

1/2

1/2

1/2

1/2

1/2

1/2

1/2

1

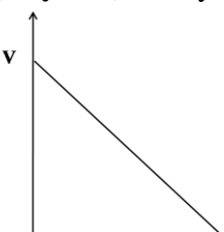
11.	<table border="1" style="width: 100%;"> <tbody> <tr> <td>a) Difference between electromagnet and permanent magnet</td> <td style="text-align: right;">1</td> </tr> <tr> <td>b) Properties of material (any two)</td> <td style="text-align: right;"><math>\frac{1}{2} + \frac{1}{2}</math></td> </tr> </tbody> </table> <p>a) An electromagnet consists of a core made of a ferromagnetic material placed inside a solenoid. It behaves like a strong magnet when current flows through the solenoid and effectively loses its magnetism when the current is switched off.</p> <p>A permanent magnet is also made up of a ferromagnetic material but it retains its magnetism at room temperature for a long time after being magnetized once.</p> <p>b) Properties</p> <ol style="list-style-type: none"> <li>i. High permeability</li> <li>ii. Low retentivity</li> <li>iii. Low coercivity (<b>Any two</b>)</li> </ol>	a) Difference between electromagnet and permanent magnet	1	b) Properties of material (any two)	$\frac{1}{2} + \frac{1}{2}$	<p style="text-align: right;"><math>\frac{1}{2}</math></p> <p style="text-align: right;"><math>\frac{1}{2}</math></p> <p style="text-align: right;"><math>\frac{1}{2} + \frac{1}{2}</math></p>	2								
a) Difference between electromagnet and permanent magnet	1														
b) Properties of material (any two)	$\frac{1}{2} + \frac{1}{2}$														
12.	<table border="1" style="width: 100%;"> <tbody> <tr> <td>Formula</td> <td style="text-align: right;">1</td> </tr> <tr> <td>Substitution and Calculation</td> <td style="text-align: right;"><math>\frac{1}{2}</math></td> </tr> <tr> <td>Result</td> <td style="text-align: right;"><math>\frac{1}{2}</math></td> </tr> </tbody> </table> $\lambda = \frac{h}{mv}$ $= \frac{6.63 \times 10^{-34}}{9.1 \times 10^{-31} \times 2.2 \times 10^8}$ $= 3.31 \times 10^{-12} \text{m}$	Formula	1	Substitution and Calculation	$\frac{1}{2}$	Result	$\frac{1}{2}$	<p style="text-align: right;">1</p> <p style="text-align: right;"><math>\frac{1}{2}</math></p> <p style="text-align: right;"><math>\frac{1}{2}</math></p>	2						
Formula	1														
Substitution and Calculation	$\frac{1}{2}$														
Result	$\frac{1}{2}$														
13.	<table border="1" style="width: 100%;"> <tbody> <tr> <td>One difference between <math>\epsilon</math> and V</td> <td style="text-align: right;"><math>\frac{1}{2}</math></td> </tr> <tr> <td>VI Graph</td> <td style="text-align: right;"><math>\frac{1}{2}</math></td> </tr> <tr> <td>Determination of 'r' and <math>\epsilon</math></td> <td style="text-align: right;">1</td> </tr> </tbody> </table> <p>Difference between emf(<math>\epsilon</math>) and terminal voltage (v)</p> <table border="1" style="width: 100%;"> <thead> <tr> <th style="text-align: center;"><math>\epsilon m f</math></th> <th style="text-align: center;">terminal voltage</th> </tr> </thead> <tbody> <tr> <td>1) It is the potential difference between two terminals of the cells when no current is drawn from it.</td> <td>1) It is the potential difference between two terminals when current passes through it.</td> </tr> <tr> <td>2) It is the cause.</td> <td>2) It is the effect.</td> </tr> </tbody> </table> <p>(<b>Any one</b>) or any other relevant difference</p> 	One difference between $\epsilon$ and V	$\frac{1}{2}$	VI Graph	$\frac{1}{2}$	Determination of 'r' and $\epsilon$	1	$\epsilon m f$	terminal voltage	1) It is the potential difference between two terminals of the cells when no current is drawn from it.	1) It is the potential difference between two terminals when current passes through it.	2) It is the cause.	2) It is the effect.	<p style="text-align: right;"><math>\frac{1}{2}</math></p> <p style="text-align: right;">1</p>	
One difference between $\epsilon$ and V	$\frac{1}{2}$														
VI Graph	$\frac{1}{2}$														
Determination of 'r' and $\epsilon$	1														
$\epsilon m f$	terminal voltage														
1) It is the potential difference between two terminals of the cells when no current is drawn from it.	1) It is the potential difference between two terminals when current passes through it.														
2) It is the cause.	2) It is the effect.														

14.

(i) Statement of Biot Savart's law	1
(ii) Expression for magnetic field	1/2
(iii) Showing field lines	1/2

(i) According to Biot Savart's law, the magnetic field due to a current element  $d\vec{\ell}$  carrying current  $I$  at a point with position  $P$  vector  $\vec{r}$  is given by

$$d\vec{B} = \frac{\mu_0}{4\pi} I \left[ \frac{d\vec{\ell} \times \vec{r}}{|\vec{r}|^3} \right]$$

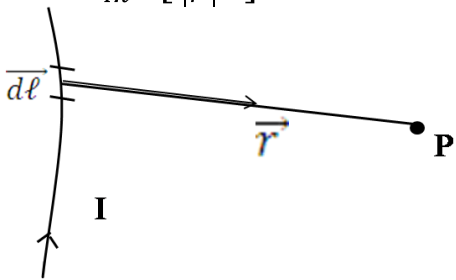

(ii)  $B = \frac{\mu_0 I}{2r}$   
Field lines

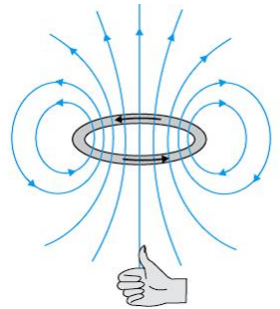

1

1/2

1/2

15.

a) Definition of stopping potential	1
b) Diagram / Plotting graph	1

a) The minimum negative potential, applied on the collector plate, that makes the photocurrent zero, is called the stopping potential.  
b)  $v_2 > v_1$

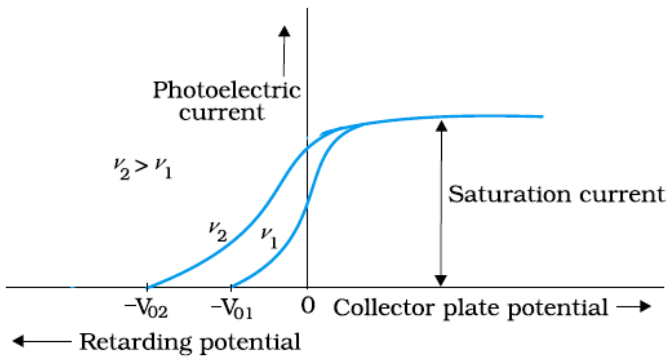

1

1

16.

a) Truth table for OR gate	1/2
Logic symbol for OR gate	1/2
b) Output waveform	1

a) Truth Table

Input		Output
A	B	Y
0	0	0
0	1	1
1	0	1
1	1	1

Logic symbol

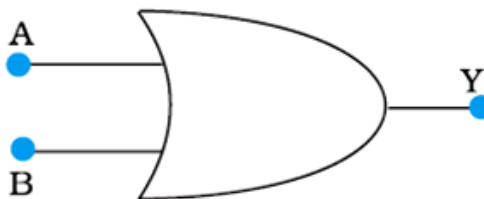

1/2 + 1/2

b)

Output waveform

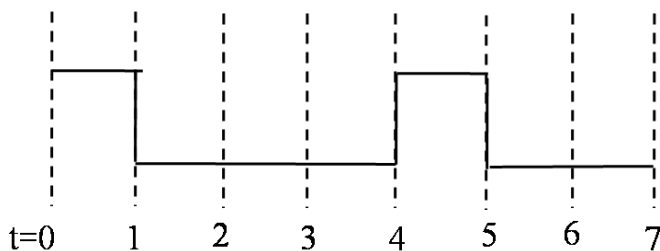

1

2

17.

(a) Conditions	1/2 + 1/2
(b) Formation of rainbow	
Diagram	1/2
Explanation	1/2

The condition for observing a rainbow are :

- i. The sun comes out after a rainfall.
- ii. The observer stands with the sun towards his/her back. (any one)

1/2

1/2

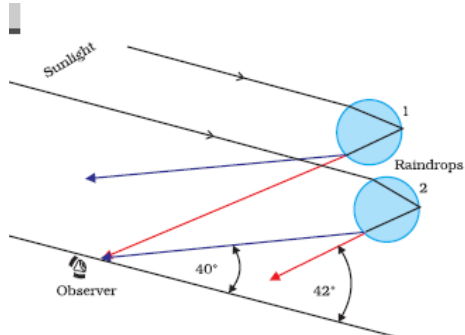

1/2

Formation of a rainbow:

→ The rays of light reach the observer through a refraction, followed by a

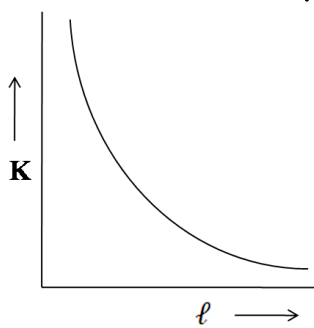
18.	<div style="border: 1px solid black; padding: 5px; margin-bottom: 10px;"> <table style="width: 100%; border-collapse: collapse;"> <tr> <td style="padding: 2px;">(i) Formula of source frequency</td> <td style="text-align: right; padding: 2px;"><math>\frac{1}{2}</math></td> </tr> <tr> <td style="padding: 2px;">Result of source frequency</td> <td style="text-align: right; padding: 2px;"><math>\frac{1}{2}</math></td> </tr> <tr> <td style="padding: 2px;">(ii) Formula of quality factor</td> <td style="text-align: right; padding: 2px;"><math>\frac{1}{2}</math></td> </tr> <tr> <td style="padding: 2px;">Result of quality factor</td> <td style="text-align: right; padding: 2px;"><math>\frac{1}{2}</math></td> </tr> </table> </div> <p>(i) <math>\omega = \frac{1}{\sqrt{LC}}</math>  <math>= \frac{1}{\sqrt{40 \times 10^{-3} \times 100 \times 10^{-6}}}</math>  <math>= 500 \text{ rad/s}</math> Or <math>\nu = \frac{500}{2\pi} \text{ hz}</math></p> <p>(ii) <math>Q = \frac{1}{R} \sqrt{\frac{L}{C}}</math> or <math>Q = \frac{\omega_0 L}{R}</math>  <math>= \frac{1}{50} \sqrt{\frac{40 \times 10^{-3}}{100 \times 10^{-6}}}</math>  <math>= 0.4</math></p>	(i) Formula of source frequency	$\frac{1}{2}$	Result of source frequency	$\frac{1}{2}$	(ii) Formula of quality factor	$\frac{1}{2}$	Result of quality factor	$\frac{1}{2}$	<p><math>\frac{1}{2}</math></p> <p><math>\frac{1}{2}</math></p> <p><math>\frac{1}{2}</math></p> <p><math>\frac{1}{2}</math></p>	2
(i) Formula of source frequency	$\frac{1}{2}$										
Result of source frequency	$\frac{1}{2}$										
(ii) Formula of quality factor	$\frac{1}{2}$										
Result of quality factor	$\frac{1}{2}$										
19.	<div style="border: 1px solid black; padding: 5px; margin-bottom: 10px;"> <table style="width: 100%; border-collapse: collapse;"> <tr> <td style="padding: 2px;">(a) Principle of potentiometer</td> <td style="text-align: right; padding: 2px;"><math>\frac{1}{2}</math></td> </tr> <tr> <td style="padding: 2px;">Reason for Part (i), (ii) and (iii)</td> <td style="text-align: right; padding: 2px;"><math>\frac{1}{2} + \frac{1}{2} + \frac{1}{2}</math></td> </tr> <tr> <td style="padding: 2px;">(b) Graph</td> <td style="text-align: right; padding: 2px;">1</td> </tr> </table> </div> <p>a) Principle of potentiometer:  The potential drop across the length of a steady current carrying wire of uniform cross section is proportional to the length of the wire.</p> <ol style="list-style-type: none"> <li>i. We use a long wire to have a lower value of potential gradient (i.e. a lower 'least count' or greater sensitivity of the potentiometer) <span style="float: right;"><math>\frac{1}{2}</math></span></li> <li>ii. The area of cross section has to be uniform to get a 'uniform wire' as per the principle of the potentiometer / to ensure a constant value of resistance per unit length of the wire. <span style="float: right;"><math>\frac{1}{2}</math></span></li> <li>iii. The emf of the driving cell has to be greater than the emf of the primary cells as otherwise no balance point would be obtained. <span style="float: right;"><math>\frac{1}{2}</math></span></li> </ol> <p>b) Potential gradient <math>K = \frac{V}{L}</math>  <math>\therefore</math> the required graph is as shown</p> <div style="text-align: center;">  </div>	(a) Principle of potentiometer	$\frac{1}{2}$	Reason for Part (i), (ii) and (iii)	$\frac{1}{2} + \frac{1}{2} + \frac{1}{2}$	(b) Graph	1	<p><math>\frac{1}{2}</math></p> <p><math>\frac{1}{2}</math></p> <p><math>\frac{1}{2}</math></p> <p><math>\frac{1}{2}</math></p> <p>1</p>	3		
(a) Principle of potentiometer	$\frac{1}{2}$										
Reason for Part (i), (ii) and (iii)	$\frac{1}{2} + \frac{1}{2} + \frac{1}{2}$										
(b) Graph	1										



- |                                                            |     |
|------------------------------------------------------------|-----|
| (a) Reason for momentary deflection                        | 1/2 |
| Deflection after the capacitor gets fully charged          | 1/2 |
| (b) Explanation for modification in Ampere's circuital law | 2   |

- (a) The momentary deflection is due to the transient current flowing through the circuit when the capacitor is getting charged. 1/2  
The deflection would be zero when the capacitor gets fully charged. 1/2
- (b) We consider the charging of a capacitor when it is being charged by connecting it to a dc source.

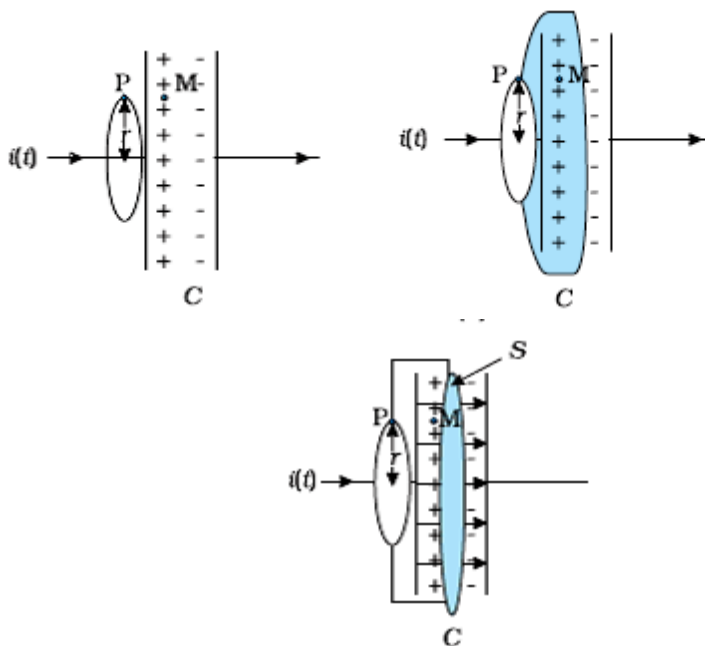

In Ampere's circuital law, namely

$$B (2\pi r) = \mu_0 i$$

We have  $i$  as non zero for surface (a) but zero for surface (c)

Hence there is a contradiction in the value of  $B$ ; calculated one way we have a magnetic field at  $P$  but calculated another way we have  $B=0$

To remove this contradiction the concept of displacement current

$$(i_d = \epsilon_0 \frac{d\phi_E}{dt} = i) \text{ was introduced}$$

and Ampere's circuital law was put in its generalized form namely

$$\oint_B \vec{\cdot} d\vec{l} = \mu_0 i_c + \mu_0 \epsilon_0 \frac{d\phi_E}{dt}$$

This form gives consistent results for values of  $B$  irrespective of which surface is used to calculate it.

1/2

1/2

1/2

1/2

1/2

1/2



21.

- |      |                              |   |
|------|------------------------------|---|
| (i)  | Magnitude of Resultant field | 2 |
| (ii) | Direction of Resultant field | 1 |

(i) Magnitude

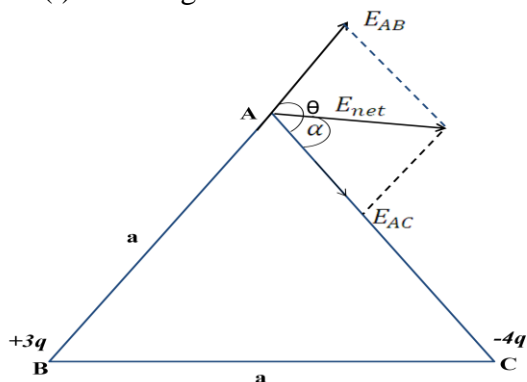
 $\frac{1}{2}$ 

$$\left| \vec{E}_{AB} \right| = \frac{1}{4\pi\epsilon_0} \frac{3q}{a^2} = 3E, \text{ where } E = \frac{1}{4\pi\epsilon_0} \frac{q}{a^2}$$

 $\frac{1}{2}$ 

$$\left| \vec{E}_{AC} \right| = \frac{1}{4\pi\epsilon_0} \frac{4q}{a^2} = 4E$$

 $\frac{1}{2}$ 

$$\begin{aligned} E_{net} &= \sqrt{(3E)^2 + (4E)^2 + 2(3E)(4E)\cos(120^\circ)} \\ &= \sqrt{9E^2 + 16E^2 - 12E^2} \\ &= E\sqrt{13} = \frac{1}{4\pi\epsilon_0} \frac{q\sqrt{13}}{a^2} \end{aligned}$$

 $\frac{1}{2}$ 

(ii) Direction

$$\tan \alpha = \frac{|E_{AB}| \sin 120^\circ}{|E_{AC}| + |E_{AB}| \cos 120^\circ}$$

 $\frac{1}{2}$ 

$$= \frac{3E \times \frac{\sqrt{3}}{2}}{4E + 3E \times -\left(\frac{1}{2}\right)} = \frac{3E\sqrt{3} \times 2}{2 \times 5E}$$

$$\alpha = \tan^{-1} \left( \frac{3\sqrt{3}}{5} \right)$$

 $\frac{1}{2}$ 

22.

- |     |                                       |                             |
|-----|---------------------------------------|-----------------------------|
| (a) | Reason                                | 1                           |
| (b) | Any two values                        | $\frac{1}{2} + \frac{1}{2}$ |
| (c) | Determination of sideband frequencies | $\frac{1}{2} + \frac{1}{2}$ |

(a) The ultra high frequency em radiations, continuously emitted by a mobile phone, may harm the system of the human body.

1

(b) Sister Anita shows





(c) The side bands are  
 $(\nu_e + \nu_m)$  and  $(\nu_e - \nu_m)$   
 or  $(1000 + 10) \text{ kHz}$  and  $(1000 - 10) \text{ kHz}$   
 $1010 \text{ kHz}$  and  $990 \text{ kHz}$

$\frac{1}{2}$   
 $\frac{1}{2}$

3

23.

- |                                                |                             |
|------------------------------------------------|-----------------------------|
| (a) Difference between a solenoid and a toroid | 1                           |
| (b) Derivation of the relation $B = \mu_0 n I$ | 1                           |
| (c) Magnetic field (i) inside and (ii) outside | $\frac{1}{2} + \frac{1}{2}$ |

(a) A toroid can be viewed as a solenoid which has been bent into a circular shape to close on itself

1

(b)

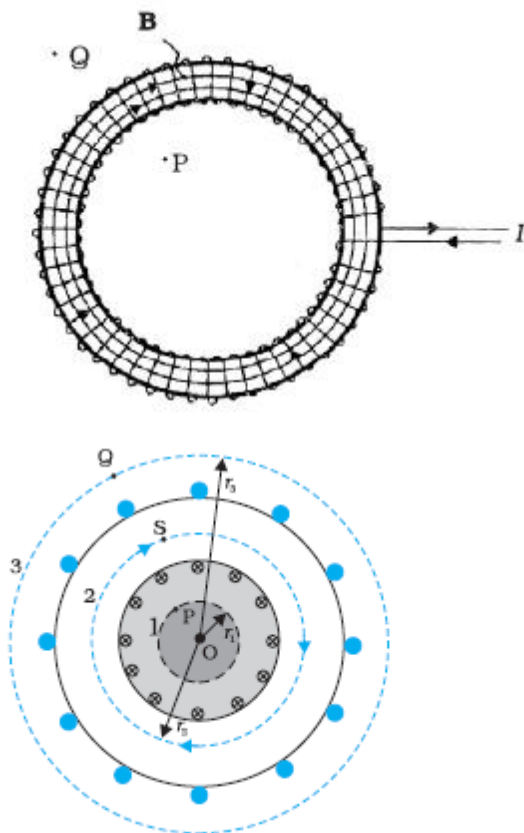

$\frac{1}{2}$

For the magnetic field at a point  $S$  inside a toroid we have

$$B(2\pi r) = \mu_0 NI$$

$$B = \mu_0 \frac{NI}{2\pi r} = \mu_0 n I \quad (\text{n = no. of turns per unit length of solenoid})$$

$\frac{1}{2}$

(c) For the loop 1. Ampere's circuital law gives

$\frac{1}{2}$

Also at point Q, we have  $B_3(2\pi r_3) = \mu_0(I_{enclosed})$   
 But from the sectional cut, we see that the current coming out of the plane of the paper, is cancelled exactly by the current going into it.  
 Hence  $I_{enclosed}=0$   
 $\therefore B_3 = 0$

1/2

3

OR

Derivation of the expression for magnetic moment	2 1/2
Direction of magnetic moment	1/2

We have  $\mu = iA$   
 $= \frac{e \cdot v}{2\pi r} \cdot \pi r^2$

$= \frac{evr}{2}$

$\ell = mvr$

$vr = \frac{\ell}{m}$

$\vec{\mu} = \frac{-e\vec{\ell}}{2m}$

The direction of  $\vec{\mu}$  is opposite to that of  $\vec{\ell}$  because of the negative charge of the electron.

1/2

1/2

1/2

1/2

1/2

1/2

3

24.

(i) Relation between average life and half life	1
(ii) Calculation for activity	2

(i) Average Life  $\tau = \frac{T_{1/2}}{0.693}$

(ii) Activity =  $\lambda N$

$$= \frac{0.6931}{28} \times 15 \times 10^{-3} \times 75 \times 10^{20} \text{ year}^{-1}$$

$$= \frac{1125 \times 0.6931}{28} \times 10^{17} \text{ year}^{-1}$$

$$= 2.81 \times 10^{18} \text{ yr}^{-1} \text{ or } = 8.81 \times 10^{10} \text{ s}^{-1}$$

[Note: There is a misprint in this part of question. Award last 1 mark of the second part even if the candidate attempts.]

1

1/2

1/2

1

3

25.

(a) Derivation of the result $I = 4I_0 \cos^2 \frac{\phi}{2}$	2
(b) Conditions for constructive and destructive interference	1/2
	1/2

(a) The resultant displacement is given by :  
 $y = y_1 + y_2$



	$\therefore R^2 = a^2(1 + \cos^2\phi + 2\cos\phi) + a^2\sin^2\phi$ $= 2a^2(1 + \cos\phi) = 4a^2\cos^2\frac{\phi}{2}$ $\therefore I = R^2 = 4a^2\cos^2\frac{\phi}{2} = 4I_0\cos^2\frac{\phi}{2}$ <p>For constructive interference ,</p> $\cos\frac{\phi}{2} = \pm 1 \text{ or } \frac{\phi}{2} = n\pi \text{ or } \phi = 2n\pi$ <p>For destructive interference ,</p> $\cos\frac{\phi}{2} = 0 \text{ or } \frac{\phi}{2} = (2n+1)\frac{\pi}{2} \text{ or } \phi = (2n+1)\pi$	1/2																
	$\cos\frac{\phi}{2} = \pm 1 \text{ or } \frac{\phi}{2} = n\pi \text{ or } \phi = 2n\pi$ <p>For destructive interference ,</p> $\cos\frac{\phi}{2} = 0 \text{ or } \frac{\phi}{2} = (2n+1)\frac{\pi}{2} \text{ or } \phi = (2n+1)\pi$	1/2	3															
26.	<table border="1"> <tbody> <tr> <td>(i)</td> <td>Formula</td> <td>1/2</td> </tr> <tr> <td></td> <td>Energy in the first excited state</td> <td>1/2</td> </tr> <tr> <td></td> <td>Energy required</td> <td>1/2</td> </tr> <tr> <td>(ii)</td> <td>Kinetic energy</td> <td>1/2</td> </tr> <tr> <td></td> <td>Orbital radius (Formula and Result)</td> <td>1/2 + 1/2</td> </tr> </tbody> </table> <p>(i) For the hydrogen atom</p> <p>a. <math> E_n  \propto \frac{1}{n^2}</math></p> <p>b. <math>\therefore</math> Energy of first excited state = <math>\frac{-13.6}{2^2} = -3.4\text{eV}</math></p> <p>c. <math>\therefore</math> Energy required = <math>[-3.4 - (-13.6)]\text{eV} = 10.2\text{eV}</math></p> <p>(ii)</p> <p>a. Kinetic energy =  energy of 1st excited state  = 3.4 eV</p> <p>b. Orbital radius in nth state <math>\propto n^2</math> = <math>4 \times 0.53\text{\AA}</math> = <math>2.12\text{\AA}</math></p>	(i)	Formula	1/2		Energy in the first excited state	1/2		Energy required	1/2	(ii)	Kinetic energy	1/2		Orbital radius (Formula and Result)	1/2 + 1/2	1/2	3
(i)	Formula	1/2																
	Energy in the first excited state	1/2																
	Energy required	1/2																
(ii)	Kinetic energy	1/2																
	Orbital radius (Formula and Result)	1/2 + 1/2																
27.	<table border="1"> <tbody> <tr> <td>(a)</td> <td>Graph showing variation of intensity with <math>\theta</math></td> <td>1</td> </tr> <tr> <td>(b)</td> <td>Determination of values of <math>\theta</math> and <math>\beta</math></td> <td>1+1</td> </tr> </tbody> </table> <p>(a) The required graph would have the form shown as:</p>	(a)	Graph showing variation of intensity with $\theta$	1	(b)	Determination of values of $\theta$ and $\beta$	1+1	1										
(a)	Graph showing variation of intensity with $\theta$	1																
(b)	Determination of values of $\theta$ and $\beta$	1+1																



(b)  $I_1 =$  Light transmitted by  $P_1$   
 $I_3 =$  Light transmitted by  $P_3 = I_1 \cos^2 \beta$   
 $I_2 =$  Light transmitted by  $P_2 = I_3 \cos^2(\theta - \beta)$   
Alternatively, (Award mark to student who indicates correct value of  $I_1, I_2$  and  $I_3$  by making a diagram)

$$\therefore I_2 = I_3$$

$$I_1 \cos^2 \beta \cdot \cos^2(\theta - \beta) = I_1 \cos^2 \beta$$

$$\theta = \beta$$

Also  $I_1 = I_2$   
 $I_1 = I_1 \cos^2 \beta \cdot \cos^2(\theta - \beta)$   
 or  $\cos^2 \theta = 1$   
 $\therefore \theta = 0^\circ$  or  $\pi$   
 Therefore  $\beta = 0^\circ$  or  $\pi$

1/2  
1/2  
1/2  
1/2

3

28.

(a) Circuit arrangement of p-n junction in

- |                      |     |
|----------------------|-----|
| (i) Forward biasing  | 1/2 |
| (ii) Reverse biasing | 1/2 |
| VI characteristics   | 1   |
| Explanation          | 1/2 |

- |                     |     |
|---------------------|-----|
| (b) Circuit diagram | 1/2 |
| Explanation         | 2   |

(a)

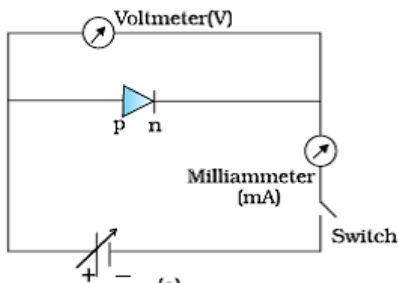

**Forward biasing**

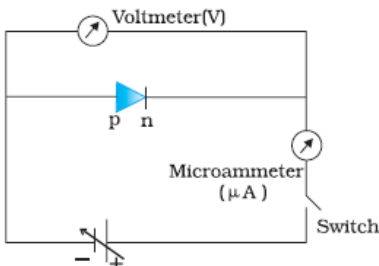

**Reverse biasing**

1/2  
1/2



The V-I characteristics ,of a diode, have the form shown here.

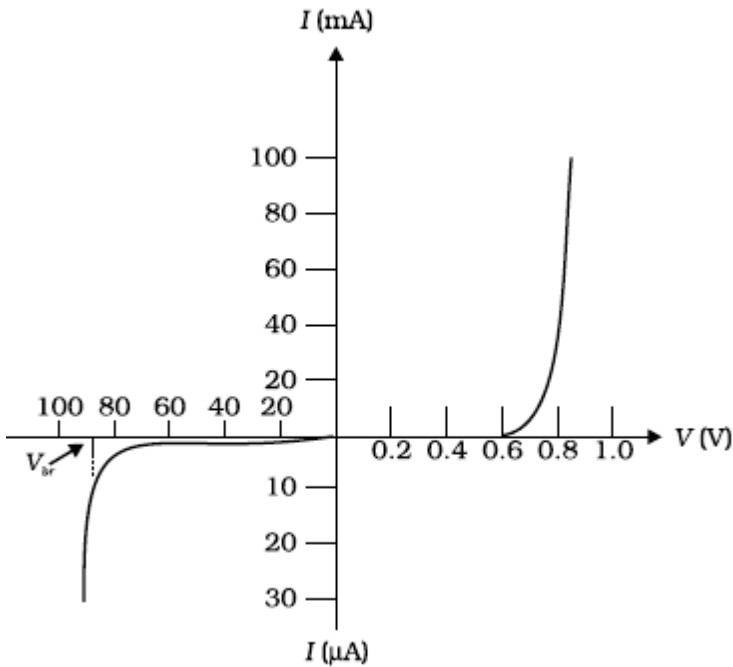

1/2+ 1/2

(b) The circuit diagram, for the photodiode, is shown here.

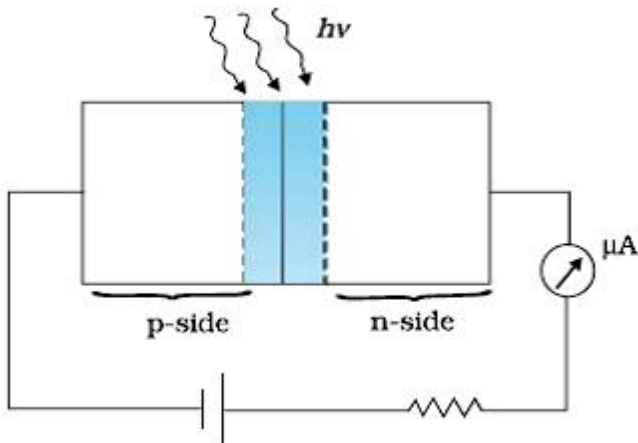

1/2

The photodiode is illuminated by optical signal, whose photon energy is greater than the energy gap of the semiconductor used.

1/2

The electric field, at the junction, separates the electrons and holes and thus gives rise to an emf.

1/2

When an external load is connected, a (photo) current flows through it. The magnitude of this current is proportional to the intensity of light incident on the photodiode.

1/2

5

(a) Circuit diagram	1
Description of current formation	1
Deduction of $I_e = I_b + I_c$	1/2
(b) Circuit diagram	1
Working	1 1/2

a) The circuit diagram is shown here

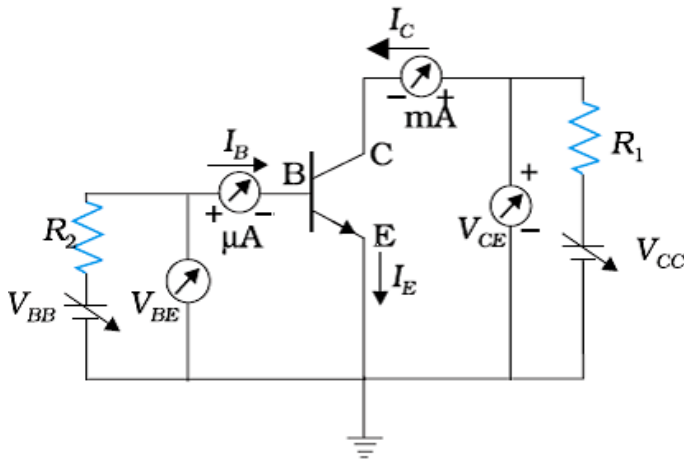

The emitter-base junction, being forward biased, the majority charge carriers (electrons), from the emitter, flow into the base region constituting the emitter current ( $I_E$ )

The base region, being very thin, only a (very) small fraction, of these charge carriers, swamps the holes present in the base region resulting in a (small) base current ( $I_B$ ).

The majority of these charge carriers, are attracted by the (reverse biased) collector. These make up the collector current ( $I_C$ ).

It is clear, therefore, that

$$I_E = I_C + I_B$$

b) The circuit diagram, of a transistor, working as an amplifier, in its CE mode, is shown here.

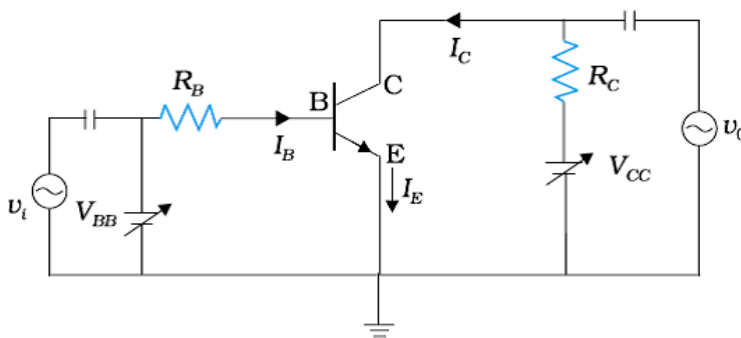

If a small sinusoidal voltage is superimposed on the dc base bias by connecting the

1

1

1/2

1



(a) Schematic arrangement	1
(b) Principle of a transformer Obtaining expression	1/2
(i) $\frac{V_1}{V_2} = \frac{N_1}{N_2}$	1
(ii) $\frac{V_1}{V_2} = \frac{I_2}{I_1}$	1
(c) Assumptions ( <b>any one</b> )	1/2
(d) Two reasons for energy losses	1/2 + 1/2

a)

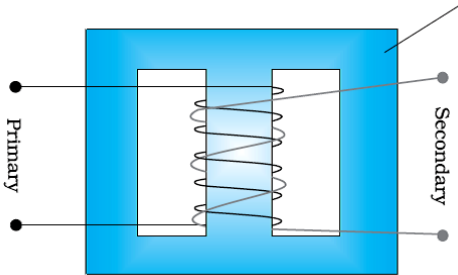

1

b) Principle of a transformer: when alternating current flows through the primary coil, an emf is induced in the neighbouring (secondary) coil

1/2

(i) Let  $\frac{d\phi}{dt}$  be the rate of change of flux through each turn of the primary and the secondary coil

$$\frac{e_1}{e_2} = -N_1 \frac{d\phi}{dt} / -N_2 \frac{d\phi}{dt} = \frac{N_1}{N_2}$$

1/2

or

$$\frac{V_1}{V_2} = \frac{N_1}{N_2} \text{ -----(1)}$$

1/2

(ii) But for an ideal transformer  $V_1 I_1 = V_2 I_2$

$$\frac{V_1}{V_2} = \frac{I_2}{I_1} \text{ -----(2)}$$

1/2

From equation (1) and (2)

$$\frac{V_1}{V_2} = \frac{N_1}{N_2} = \frac{I_2}{I_1}$$

1/2

c) Main assumptions

- (i) The primary resistance and current are small
  - (ii) The flux linked with the primary and secondary coils is same / there is no leakage of flux from the core.
  - (iii) Secondary current is small
- (**Any one**)

1/2

d) Reason due to which energy losses may occur

Flux leakage/resistance of the coils / eddy currents / Hysteresis (**Any two**)

1/2 + 1/2

5

a) Derivation of the expressions for	2 ½
i. Induced emf	
ii. Induced current	
b) Expression for magnitude of force and its direction	1½
c) Expression for power	1

a) In one revolution

Change of area,  $dA = \pi \ell^2$

$\therefore$  change of magnetic flux

$$d\phi = \vec{B} \cdot d\vec{A} = BdA \cos 0^\circ$$

$$= B \pi \ell^2$$

Period of revolution T

(i) Induced emf  $\varepsilon = B\pi\ell^2/T = B\pi\ell^2v$

(ii) Induced current in the rod,  $I = \frac{\varepsilon}{R} = \frac{\pi v B \ell^2}{R}$

[Note: Award 2 marks if the student derives the above relation using other method.]

b) Force acting on the rod,  $F = I\ell B$

$$= \frac{\pi v B^2 \ell^3}{R}$$

The external force required to rotate the rod opposes the Lorentz force acting on the rod / external force acts in the direction opposite to the Lorentz force

c) Power required to rotate the rod

$$P = F \cdot v$$

$$= \frac{\pi v B^2 \ell^3 v}{R}$$

½  
½

1  
½

½

½

½

½

½

30.

a) Ray diagram	1
Derivation of lens maker's formula	2 ½
b) Calculation of radius of curvature	1 ½

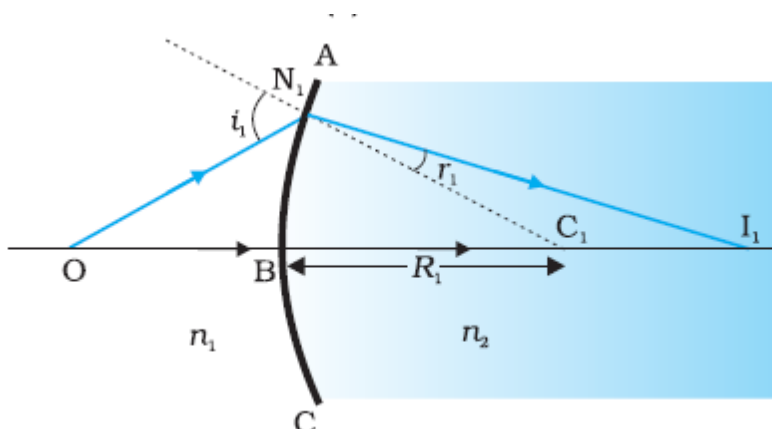

½

5



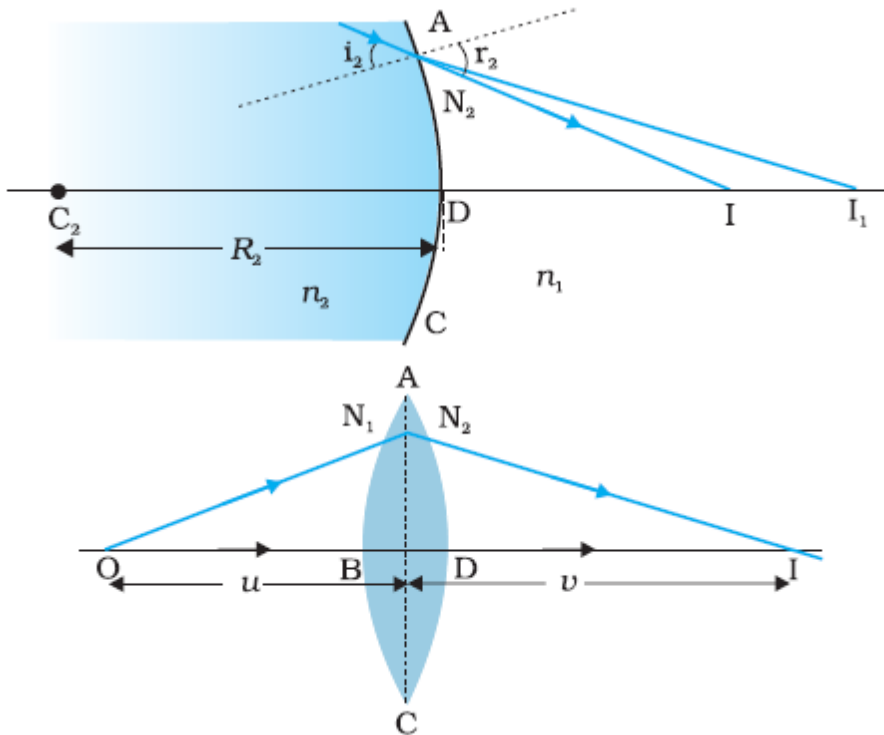

1/2

1/2

The first refracting surface ABC forms the image  $I_1$  of the object O. The image  $I_1$  acts as a virtual object for the second refracting surface ADC which forms the real image I as shown in the diagram

For refraction at ABC

$$\frac{n_2}{v_1} - \frac{n_1}{u} = \frac{n_2 - n_1}{R_1} \text{ ----- (i)}$$

1/2

For refraction at ADC

$$\frac{n_2}{v} - \frac{n_1}{u} = \frac{n_1 - n_2}{R_{12}} \text{ ----- (ii)}$$

1/2

Adding equation (i) and equation (ii)

$$\frac{n_1}{v} - \frac{n_1}{u} = (n_2 - n_1) \left( \frac{1}{R_1} - \frac{1}{R_2} \right)$$

$$\frac{1}{v} - \frac{1}{u} = \left( \frac{n_2}{n_1} - 1 \right) \left( \frac{1}{R_1} - \frac{1}{R_2} \right)$$

1/2

We know If  $u = \infty, v = f$

$$\frac{1}{v} - \frac{1}{u} = \frac{1}{f}$$

$$\frac{1}{f} = (n_2 - 1) \left( \frac{1}{R_1} - \frac{1}{R_2} \right)$$

1/2

... 1 ... (1 - 1)

$$= 0.55 \times \frac{2}{R}$$

$$R = 0.55 \times 2 \times 20 = 22 \text{ cm}$$

OR

- |                                               |     |
|-----------------------------------------------|-----|
| (a) Labelled ray diagram                      | 1 ½ |
| Derivation of expression for magnifying power | 1 ½ |
| (b) Determination of total magnification      | 2   |

a)

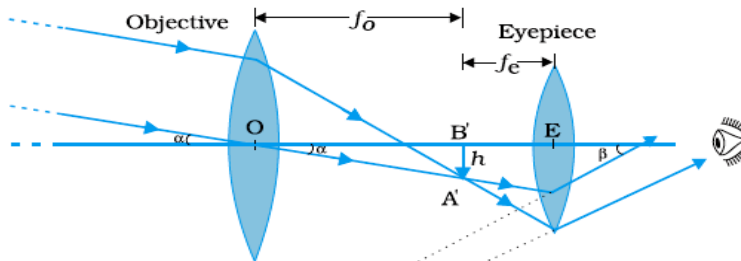

1 ½

[Note : deduct ½ mark if not labelled]

Derivation

Magnifying Power

$$M = \frac{\tan \beta}{\tan \alpha} \cong \frac{\beta}{\alpha}$$

Final image is formed at infinity when the image  $A'B'$  is formed by the objective lens at the focus of the eye piece

$$m = \frac{h}{f_e} \times \frac{f_o}{h}$$

$$= \frac{f_o}{f_e}$$

½

½

½

b) Given

$$f_0 + f_e = 105, f_0 = 20 f_e$$

$$20 f_e + f_e = 105$$

$$f_e = \frac{105}{21} = 5 \text{ cm}$$

$$f_0 = 20 \times 5 = 100 \text{ cm}$$

$$\therefore \text{Magnification } m = \frac{f_0}{f_e} = \frac{100}{5} = 20$$

½

½

½

½

5

